

Deity Connect Deluxe Kit

Transmit+Receive+Record

Product Manual

English

Foreword

Thank you for purchasing the Deity Connect Deluxe Kit.

Instructions

- Please read this product manual carefully.
- Keep this product manual. Always include this product manual when passing the products on to third parties.
- Heed all warnings and follow all instructions in this product manual.



WARNING: Do not place the product near any corrosive chemicals. Corrosion may cause the product to malfunction.

- Only use a microfiber or dry cloth to clean the product.
- Operate carefully - dropping or hitting the product may cause damage.
- Keep all liquids away from the product. Liquids entering the product can short-circuit the electronics or damage the mechanics.
- Store the product in a dry, clean, dust-free environment.
- If your product malfunctions, please have it serviced by an authorized shop. The warranty does not cover repairs to devices that have been subjected to unauthorized disassembly, although you may request such repairs on a chargeable basis.
- The product is certified by RoHS, CE, FCC, KCC and Japan MIC. Please adhere to the operation standards. The warranty does not cover repairs arising out of the misuse of the product, although you may request such repairs on a chargeable basis.
- The instructions and information in this manual are based on thorough, controlled company testing procedures. Further notice will not be given if the design and specifications change.

FCC Compliance Statement

This device complies with Part 15 of the FCC Rules. Operation is subject to the following two conditions:

(1) This device may not cause harmful interference, and (2) This device must accept any interference received, including interference that may cause undesired operation.

Warning: Changes or modifications not expressly approved by the party responsible for compliance could void the user's authority to operate the equipment.

NOTE: This equipment has been tested and found to comply with the limits for a Class B digital device, pursuant to Part 15 of the FCC Rules. These limits are designed to provide reasonable protection against harmful interference in a residential installation. This equipment generates, uses, and can radiate radio frequency energy and, if not installed and used in accordance with the instructions, may cause harmful interference to radio communications. However, there is no guarantee that interference will not occur in a particular installation. If this equipment does cause harmful interference to radio or television reception, which can be determined by turning the equipment off and on, the user is encouraged to try to correct the interference by one or more of the following measures:

- Reorientate or relocate the receiving antenna.
- Increase the distance separating the equipment and receiver.
- Connect the device to a different power supply than that which the receiver is connected to.
- Consult the dealer or an experienced radio/TV technician for help.

RF warning statement:

The device has been evaluated to meet general RF exposure requirement. The device can be used in portable exposure condition without restriction.

Intended Use

Intended use of the Deity Connect Deluxe Kit includes:

- The user has read the instructions of this manual.
- The user is using the products within the operating conditions and limitations described in this product manual.
- "Improper use" means using the products other than as described in these instructions or under operating conditions which differ from those described herein.

Item check list

Package includes the following items:

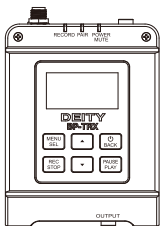

BP-TRX (2 pcs)



Receiver(DUO-RX) with hook-and-loop strap (1pc)

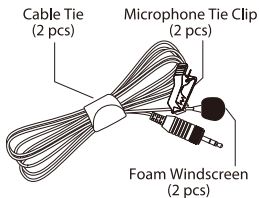

W.Lav Pro TRS Lavalier Microphone (2 pcs)

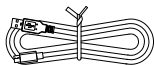

Type-C charging & Data cable(2 pcs)



Time Code Sync & Audio Cable (1 pcs)



3.5mm TRS to 3-pin XLR Audio Cable (2 pcs)



BP-TRX External Antenna (2 pcs)



DUO-RX Antenna (2 pcs)



USB-C to USB-A Firmware Update Adapter (1 pc)



Cold Shoe (1 pc)

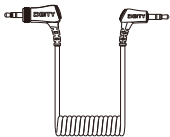

Locking TRS to TRS Coiled Audio Cable (1 pc)

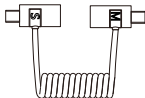

Sync Cable (1 pc)



Product manual (1 pc)



Warranty card (1 pc)

Nomenclature

1. Transmitter (BP-TRX)

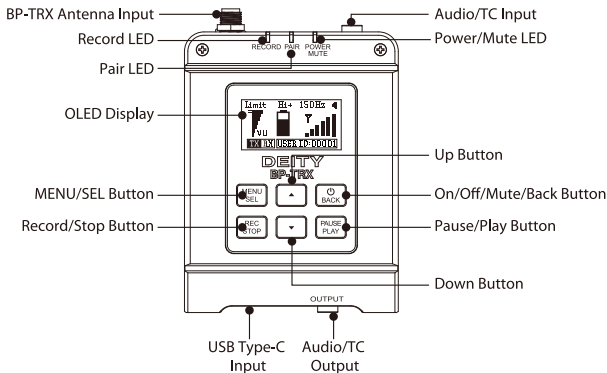

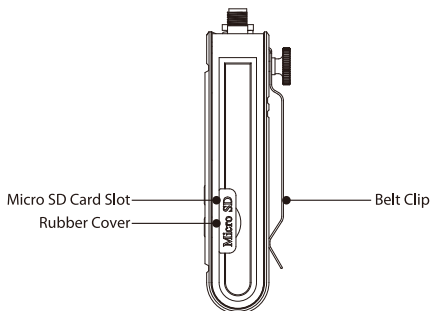

2. Receiver (DUO-RX)

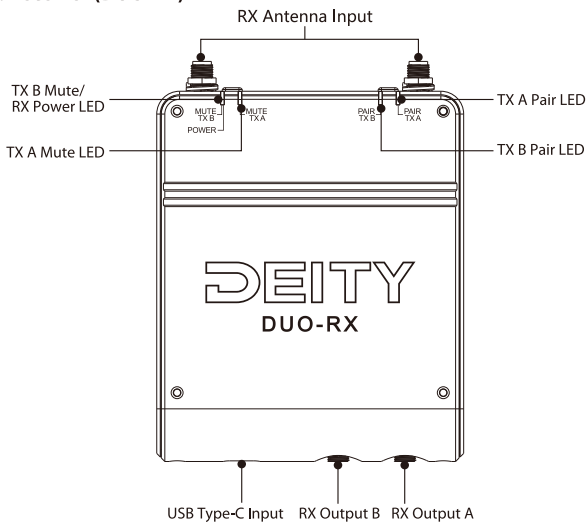

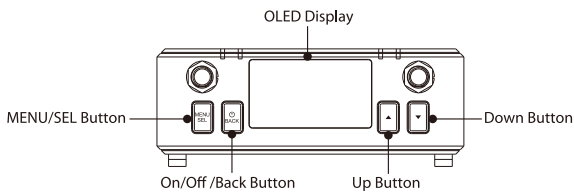
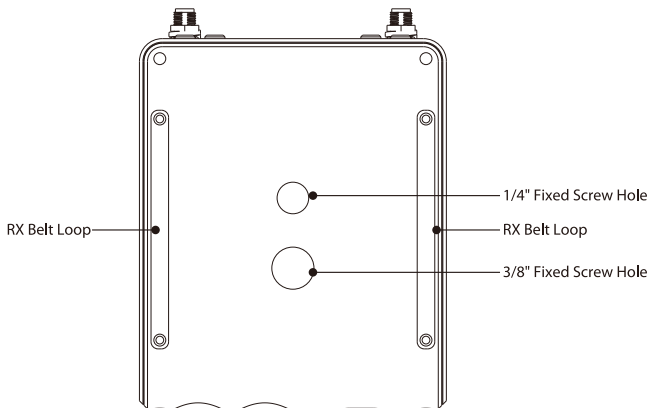

Installations and Use

1. Antenna Installation

1) BP-TRX Antenna Installation

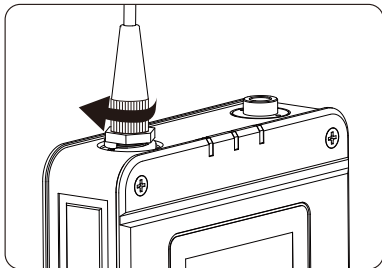

** When installed, the BP-TRX antenna points away from the body (belt clip), which helps improve the transmission range.*

2) DUO-RX Antenna Installation

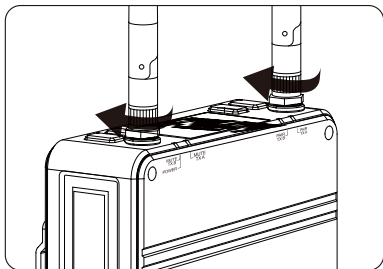

2. Lavalier Microphone Installation

The BP-TRX has a locking 3.5mm TRS connection. Simply clip the Lavalier Microphone onto your clothes and screw it into the BP-TRX TRS microphone input.

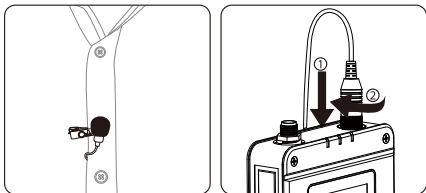

3. Use of the BP-TRX Belt Clip

The BP-TRX can be attached to the user's belt or clothing via the included belt clip.

4. Receiver Installation

The Receiver (DUO-RX) can be installed in a sound bag using the Hook and Loop Strap, or it can be mounted to the camera with the equipped Cold Shoe Mount.

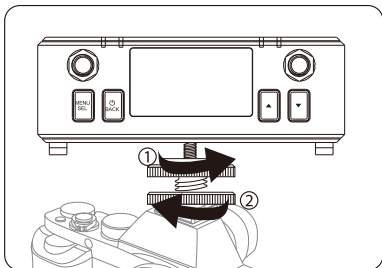

Functions and Operations

1. On/Off /Back Button

Long press  to turn the BP-TRX on and off. It also functions as a “back” button while navigating the various menus and setup screens to return to the previous screen or menu item.

2. MENU/SEL Button

This button is used to enter the menu and select highlighted items.

3. Up/Down Buttons

The Up and Down buttons are used to select various options and adjust values in the setup screens.

- * *When the screen is locked, short press the Up button 3 times to unlock the screen.*
- * *From the main screen, long press the Down button to enter the timecode settings page directly.*
- * *When recording, the up/down buttons can increase/decrease the microphone gain.*
- * *When playing back audio files, the up/down buttons can increase/decrease volume.*
- * *Playing back the audio file, long press the up/down button can switch to the last/next audio file.*

4. Language Setting

Enter the “LANGUAGE” option in the SYSTEM SET menu to select the language (system default English).

5. TRX Mode Selection

Short press the MENU/SEL Button to enter the “TRX mode” option for selecting the working mode of BP-TRX according to your needs, there are seven mode options: TX+REC, RX MODE, MASTER TX, IEM MODE, CAMERA HOP, TC BOX, REC ONLY.

(1)

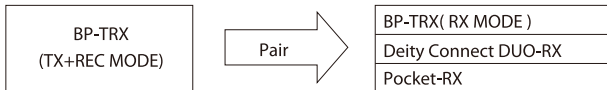

TX+REC: The BP-TRX will act as a transmitter with built in recording. By pressing the REC button on the unit (or on a paired BP-TRX set to receiver, or the UP-button of the DUO-RX) the recorder will start or stop. Pre-jammed SMTP timecode will be stamped in the header of the BWF-file. The USB port will output digital audio (USB-C AD-converter).

(2)

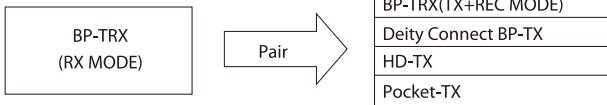

RX: The BP-TRX will act as a receiver. The REC button controls the recorder on the paired BP-TRX or the HD-TX. The paired TX can be controlled via the receiver menu. The USB port will output digital audio.

(3)

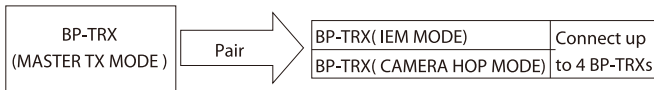

MASTER TX: The unit can pair up to 4 BP-TRXs (set to IEM or CAMERA HOP MODE). The internal recording on the MASTER TX can also be used simultaneously. Pre-jammed SMPTE timecode will be stamped in the header of the BWF-file. The USB port will output digital audio.

(4)

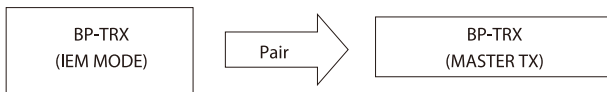

IEM: The unit can pair with the BP-TRX (set to Master TX mode) and will receive the audio. Four units can be paired to one Master TX. (IEM = In Ear Monitor). The USB port will output digital audio.

(5)

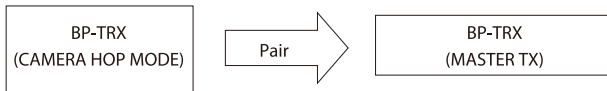

CAMERA HOP: The unit pair with the the BP-TRX (set to Master TX mode) and will receive the audio. Four units can be paired to one Master TX. The output can be a combination of timecode and audio, or audio only. The USB port will output digital audio.

(6) **TC BOX:** The unit will act as a stand-alone timecode device. Audio input supports timecode in for jam syncing. Audio output can output the timecode.

(7) **REC ONLY:** The unit will act as a stand-alone recorder with timecode. Prejammed SMPTE timecode will be stamped in the header of the BWF-file. The USB port will output digital audio (USB-C AD-converter). The USB port will output digital audio.

6. User ID Setting

Enter the "USER ID" option in the menu to set the BP-TRX's User ID to identify different BP-TRXs.

7. Pair Setting

The BP-TRX uses Easy-pair™ technology. After setting the working mode of BP-TRX, enter the "PAIR" option in the Transmitter and Receiver menu respectively, select "YES" to pair. The Transmitter and Receiver will automatically finish the pairing within 15 seconds, and the Pair LEDs flash green to indicate pairing. The green LEDs stay on to indicate that the pairing was successful and if the green LEDs flash slowly, the pairing was unsuccessful. Meanwhile, a pop-up window will indicate if your pairing was successful or not.

8. Auto-lock Setting

Enter the "AUTO-LOCK" option in the SYSTEM SET menu to set the lock screen time (system default 15s). Never, Manual, 5s, 10s, 15s, 20s, 1min, 2min, 5min, 10min.

** When the screen is locked, the buttons will not work. This helps to prevent settings from changing during operation. To unlock the screen, press UP button 3 times. Under Manual option, press UP button 3 times to unlock screen, and press UP button 3 times again to lock screen.*

9. Input Type Setting

The BP-TRX has two input modes: STEREO mode and MONO mode. Please select the Input Type according to the audio source selected. Use STEREO mode if you are feeding a stereo signal into the BP-TRX.

10. Input Gain Setting

Enter the "INPUT GAIN" option in the BP-TRX menu to increase or decrease the audio gain as needed (matches the Transmitter gain with the audio's output level, the user's voice level and the position of the microphone). The adjustment range is from -12dB to +36dB in 3dB steps.

11. Low Cut Setting

Enter the "LOW CUT" option in the BP-TRX menu and select the desired low-cut option. Choices range from 20Hz to 200Hz in 10Hz steps, or entirely off.

Reminder: please use Low Cut function when it is necessary, otherwise wind noise and rumble might affect your recording. Low Cut is meant to reduce light wind noise.

12. Limiter Setting

Enter the "LIMITER" option in the BP-TRX menu to turn the limiter on or off as needed.

13. Freq Boost Setting

Enter the "FREQ BOOST" option in the BP-TRX menu to add high frequency boost (boost audio frequencies 7kHz-20kHz) as needed. The boost range is from 1dB to 10dB in 1dB steps.

14. RF Power Setting

Enter the "RF POWER" option in the BP-TRX or DUO-RX menu to select the RF power (5 RF output options: 10mW, 25mW, 50mW, 100mW, Auto) according to the actual recording conditions. Users can optimize the Transmitter for maximum battery life or maximum operating range.

15. Headphone Volume Setting

Enter the "HEADPHONE" option in the BP-TRX menu to adjust the monitor volume as needed. The adjustment range is from -24dB to +24dB in 1dB steps.

16. File Management

Enter the "FILE" option in the BP-TRX menu. The BP-TRX allows you to playback files, rename them, and delete takes.

17. Mute Setting

Enter the "MUTE" option in the BP-TRX menu to turn the mute function on or off as needed. When "MUTE-ON" is set in the "HOTKEY" menu of SYSTEM SET, you can also quickly the mute function on or off by short pressing  at the main screen.

* *When muted, the mute LED will flash red slowly.*

18. System Reset

Enter the "SYS RESET" option in the menu to reset the system and restore the default settings.

19. Firmware Update

Users can update firmware via U disk(exFat/FAT32 USB flash drive). When updating the firmware, please download the latest firmware to the root directory of U disk on the official website, then use the "USB-C to USB-A Firmware Update Adapter" to connect the U disk to the USB Type-C input port, select "UPDATE" option from the menu, and update the firmware following the on-screen instructions. After the firmware update is completed, the firmware version shows the latest version. Official website: <https://www.deitymic.com>

* *BP-TRX also supports firmware update via built-in MicroSD card.*

20. Date/Time Setting

Enter the "DATE/TIME" option in the SYSTEM SET menu to set the specific date and time of recording.

21. Record/Stop Button

After inserting the Micro SD card into the BP-TRX, short press the "REC/ STOP" button to start or stop recording audio files in TX or REC ONLY mode.

* *Max Card Size – 128Gb*

Card Type – microSD

Card Format – FAT32, exFAT

Max File Size – 2Gb automatically keeps recording and creates new file

File Type – 24bit/48kHz Uncompressed PCM WAV File

22. Pause/Play Button

Short press the "PAUSE/PLAY" button to play or pause the audio file recorded on the microSD card.

23. TX Remote Setting

After the Transmitter and Receiver are successfully paired, enter the "TX REMOTE" menu, then users can remotely control every audio adjustment on the Transmitter through the Receiver.

24. TX Sleep Setting

After the Transmitter and Receiver are successfully paired, users can set whether the Transmitter sleeps or not in the Receiver menu. When the sleep is turned on, the Transmitter enters a low power mode (locks screen, powers down the audio input circuitry, but keeps feeding a low power data stream to maintain the link).

25. Out Level Setting

Enter the "OUT LEVEL" option in the BP-TRX Receiver menu to adjust the output gain as needed. The adjustment range is from -45dB to +24dB in 1dB steps.

26. Out Type Setting

When the BP-TRX working mode is selected as the RX MODE, BP-TRX has four output type options: XLR, DSLR, STEREO, and SYNC.

When the BP-TRX working mode is selected as the CAMERA HOP mode, BP-TRX has two output type options: MONO and SYNC. Please set the output type according to your needs.

27. Latency Setting

Enter the "LATENCY" option in the Receiver menu to select the latency setting (LOW, MID, HIGH) according to the actual recording needs. Users can optimize the transmission distance between the Transmitter and Receiver.

28. Charging

The power LED glows green when the battery is good. The color changes to red when there is about 30 minutes of operation left. The BP-TRX supports Qualcomm QC 2.0/3.0 and MTK PE quick charge. The battery is charged using the included Type-C charging cable connected to a DC adapter (Not included).

* When charging, the power LED will flash between red and green.

* When fully charged, the power LED stays green.

29. Timecode

1) Timecode overview

The BP-TRX comes with an internal crystal based timecode generator. Timecode functionality will be available in the following TRX modes: TX+REC, RX MODE, MASTER TX, CAMERA HOP, TC BOX, REC ONLY.

Timecode is time information written to data when recording video and audio. It is used for video editing, control of other devices, and synchronization of audio and video. If video and audio data both have recorded timecode, aligning them to a timeline and synchronizing them together is easy when using nonlinear editing software.

* The product uses a precision oscillator that generates timecode with a high degree of accuracy (+/- 0.5 ppm, or approximately 1 frames per 24 hours).

* Even after powering down the BP-TRX, timecode will continue running for 6 hours.

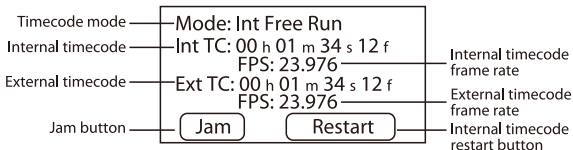

2) Timecode mode setting

The timecode mode settings allow you to specify whether the BP-TRX generates timecode or not. An internal timecode will be generated only when recording or regardless of the recording mode.

Short press MENU SEL button, select TC SYNC, press MENU SEL to enter timecode setting interface. Select the mode, press MENU SEL to select the mode you required.

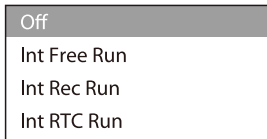
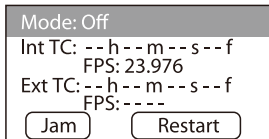

Mode Name	Explanation
Off	No timecode will be written to the recording file. Timecode will not be output from the audio output jack.
Int Free Run	Internal timecode will be generated regardless of the recording mode. The internal timecode can be set manually using the following menu items: <ul style="list-style-type: none"> • MENU SEL -> TC SYNC -> TC SETING-> Jam • MENU SEL -> TC SYNC -> TC SETING-> Restart Timecode will always be output from the audio input /output Jack.
Int Rec Run	Internal timecode will be generated only when recording. The internal timecode can be set manually using the following menu items: <ul style="list-style-type: none"> • MENU SEL -> TC SYNC -> TC SETING-> Jam • MENU SEL -> TC SYNC -> TC SETING-> Restart When switching from another mode, or when recording stops, the internal timecode will stop at the last value.
Int RTC Run	Internal timecode will be generated regardless of the recording mode. In the following situations, the internal timecode will be synchronized (jammed) with the RTC (internal clock): <ul style="list-style-type: none"> • At start up • When Date/Time (RTC) has changed (→ Item 20 Date/Time Setting) • When switching to this timecode mode Timecode will always be output from the audio in/out Jack.

3) Frame rate setting for internal timecode

You can set the frame rate for internal timecode as 23.976, 24,25, 29.97, 29.97DF, 30, 30DF. DF stands for Drop frame.

Short press MENU SEL button, select TC SYNC, press MENU SEL to enter timecode setting interface. Select the FPS, press MENU SEL to select the FPS you required. Matching frame rates must be set in advance on all connected video and audio devices.

4) Timecode jamming operation

(1) Jamming external timecode

You can use the included timecode sync & audio cable to jam the BP-TRX to an external timecode . Continue to below steps:

Short press MENU SEL button, select TC SYNC, press MENU SEL to enter timecode setting interface. When external timecode input is detected. Select JAM to sync the internal and external timecode.

(2) Jamming internal timecode

The Audio output can be engaged to give a timecode source, to connect or jam other devices, such as recorders, cameras, other BP-TRX units or third party timecode devices.

You also can use included time code sync & audio cable or TRS cable to connect BP-TRX audio output jack to external timecode input jack. Perform the time code synchronization operation as follows:

If TRX MODE sets as RX MODE or CAMERA HOP MODE, select the OUT TYPE as SYNC, press the Up or Down buttons to select TC SYNC, press MENU SEL button to select Jam to synchronize the timecode.

OUT LEVEL	0dB
OUT TYPE	XLR
LATENCY	LOW
PAIR	↶

XLR	: A+/_/G
DSLR	: A+/A+/G
HOP	: AL/AR/G
SYNC	: TC/A+/G

If TRX MODE is set to TX+REC MODE/MASTER TX MODE/TC BOX/REC ONLY, press MENU SEL button, select TC SYNC, press the down button to select OUTPUT as ON. Select Jam to synchronize the timecode. If other modes, skip this step.

** If TRX MODE is set to IEM MODE, there is no timecode output.*

Mode: Int Free Run Int TC: 00 h 01 m 34 s 12 f FPS: 23.976 Ext TC: 00 h 01 m 34 s 12 f FPS: 23.976 <input type="button" value="Jam"/> <input type="button" value="Restart"/>

5) Restarting the internal timecode with a specified value

Press MENU SEL to select "Restart" and press MENU SEL. Set the restart value. Move cursor or change value, press UP/Down button. Select parameter to change, press MENU SEL button.

** If timecode mode is set to Int RTC Run, we can't restart the internal timecode.*

Int TC: 00 h 16 m 30 s 20 f Restart Time: [00], h 00 m 00 s 00 f <input type="button" value="Restart"/>

6) Timecode level setting

To accommodate a certain TC level needed by a particular connected device, and if Ext TC is not detected during timecode synchronization, the BP-TRX can increase or decrease the voltage level of timecode output to make it to be detected. The adjustment range is from 0.5V to 3.0V in 0.1V steps. The system defaults to 2.5V.

2.5V
2.6V
2.7V
2.8V

30. Pairing the BP-TRX and the DUO-RX

1) Set the BP-TRX or BP-TRXs working mode to TX+REC MODE, and select the DUO-RX's out type as needed. Select the "PAIR" option in the Transmitter and Receiver menu respectively. The Transmitter and Receiver will automatically finish pairing.

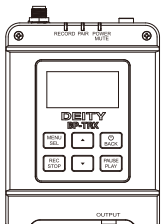

TX-A



TX-B

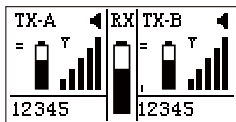

2) The DUO-RX receiver can pair up to two BP-TRX units.

The DUO RX has six output modes:

- XLR: use in combination with the included 3.5mm TRS to 3-pin XLR Audio Cable. RX output A outputs TX-A (mono signal) and RX output B outputs TX-B (mono signal).
- DSLR ISO: outputs a stereo/2 channel signal over 3.5mm Locking TRS to TRS Coiled Audio Cable.
- SOLO A: both output A and B will provide a mono signal of TX-A.
- SOLO B: both output A and B will provide a mono signal of TX-B.
- HOP A: RX output A provides a stereo signal of TX-A and output B provides a mono signal of TX-A.
- HOP B: RX output A provides a mono signal of TX-B and output B provides a stereo signal of TX-B.

OUT TYPE	XLR	: A+/_/G	DUO-RX output A
		: B+/_/G	DUO-RX output B
OUT TYPE	DSL R ISO	: A+/B+/G	DUO-RX output A
		: AB/AB/G	DUO-RX output B

3) By pressing the Up-button/Down-button of the DUO-RX, the recorder TX-A/TX-B will start or stop.

31. Use of Sync Cable

When two sets of Deity Connect Deluxe Kit are used at close range, these Receivers must be synchronized with the sync cables to reduce co-channel interference and maximize transmission distance. In order to make sure the communication is stable, two sets of DUO-RX paired to 4 BP-TRX units is the advised maximum.

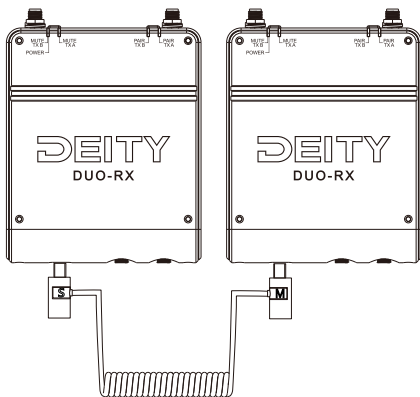

Specifications

BP-TRX	
Transmission Type	2.4 GHz
Antenna	1 x 1/4 Wave External, Detachable, SMA; 1 x 1/4 Dipole Internal
Mute Switch	Yes
Range (distance)	Up To 100m
Bitrate/Sampling Frequency	24bit/48kHz
Limiter	Analog
Signal Processing	High Pass Filter: Off, 20-200Hz; HF Boost: Off, +1dB – +10dB @ 7kHz-20kHz
Display Type	1.3" OLED Display
Battery Type	Lithium-Ion Rechargeable Battery
Battery Capacity	2800mAh
Battery Working Time	~18.5 Hrs @REC ONLY ~17 Hrs @100mw RF Output
Battery Recharge Time	~130 Minutes via USB QuickCharge 2.0/3.0
Battery Charger	USB Type-C Charging Cable
Audio Input Connector	Female Locking 3.5mm TRS
Audio Retransmission Modes	Low 19ms/ Medium 30ms/ High 40ms
Input Gain Range	-12dB to +36dB in 3dB Steps
Timecode Accuracy	+/- 0.5 ppm, or approximately 1 frames per 24 hours
LED Indicators	2 x LED (Mute, Power); 1 x LED (Sync); 1 x LED (Record)
Mounting Option	Belt Clip
Dimensions	3.6" x 2.5" x 0.91"/ 91.5mm x 63.5mm x 23mm (without Antenna)
Net Weight	158g
Temperature Range	-10 °C to +45 °C





* Run times vary based on RF Output, what recording mode, and if the unit is recording to the micro SD card. Your battery life may vary. Reducing the RF Output will increase the battery life.

DUO-RX	
Transmission Type	2.4 GHz
Range (distance)	Up To 100m
Bitrate/Sampling Frequency	24bit/48kHz
Display Type	1.3" OLED Display
Battery Type	Lithium-Ion Rechargeable Battery
Battery Capacity	2200mAh
Battery Working Time	~10 Hrs @100mw RF Output
Battery Recharge Time	~70 Minutes via USB QuickCharge 2.0/3.0
Battery Charger	USB Type-C Charging Cable
Antenna Inputs	SMA Female Connectors
RX Output Connection	Dual Female Locking 3.5mm TRS
RX Dimensions	115mm*87.4mm*33.5mm
RX Net Weight	248g
Temperature Range	-10 °C to +45 °C

W.Lav Pro TRS Lavalier Microphone

Polar Pattern	Omni-directional
Dynamic Range	85dB (per IEC651)
Maximum SPL	≥110dB(@1KHz,1% THD into 1KΩ)
Frequency Range	50Hz~20kHz
THD	≤0.5%
Output Impedance	3KΩ
Sensitivity	-41±2dB re 1V/Pa @1kHz
Signal/Noise	≥69dB SPL(@1KHz,rel 1Pa per IEC651)
Weatherproof Standard	IP57
Mic Head Size	4mm*17mm
Connector Type	3.5mm TRS
Cable Dimension	1.8M
Net Weight (Mic)	10g

Icon Description

	Mute-off
	Mute-on
	RF Level The icon changes in size horizontally to indicate the strength of the incoming RF signal.
	VU Meter The icon changes in size vertically to indicate the audio level.
	Battery Level The icon changes in size vertically to indicate the battery level.
Limit	The Limiter is On
Hi +	High Frequency Boost is On

DEITY
MICROPHONES

Inspection: Qualified

Add. F/3, Building 21, Longjun Industrial Estate, Heping West Road, Shenzhen,
Guangdong